

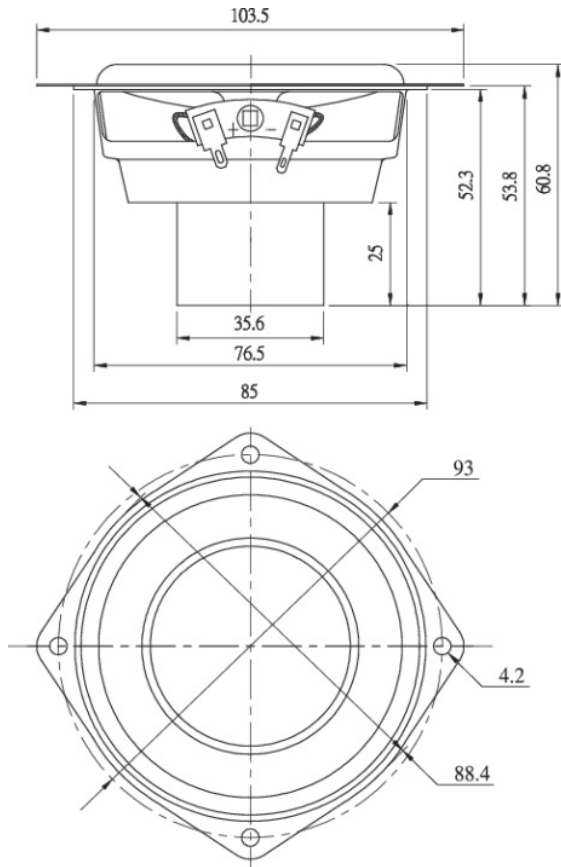

# ND90-8 3-1/2" Aluminum Cone Full-Range Driver 8 Ohm

ND90-8



## PARAMETERS

Impedance	8 ohms
Re	7.5 ohms
Le	1.08 mH @ 1 kHz
Fs	70.7 Hz
Qms	4.71
Qes	0.75
Qts	0.65
Mms	4.2g
Cms	1.22 mm/N
Sd	31.2 cm <sup>2</sup>
Vd	12.5 cm <sup>3</sup>
BL	4.3 Tm
Vas	1.77 liters
Xmax	4.0 mm
VC Diameter	19 mm
SPL	81.4 dB @ 2.83V/1m
RMS Power Handling	20 watts
Usable Frequency Range (Hz)	80 - 15,000 Hz

## FEATURES

- Direct replacement for Aura NS3
- Rubber-edged anodized aluminum alloy cone
- Large excursion capability 4 mm Xmax, 20 mm peak
- Self-shielded Neo-Balanced motor structure
- Full-range 80 Hz to 15 kHz performance

## IMPEDANCE/PHASE

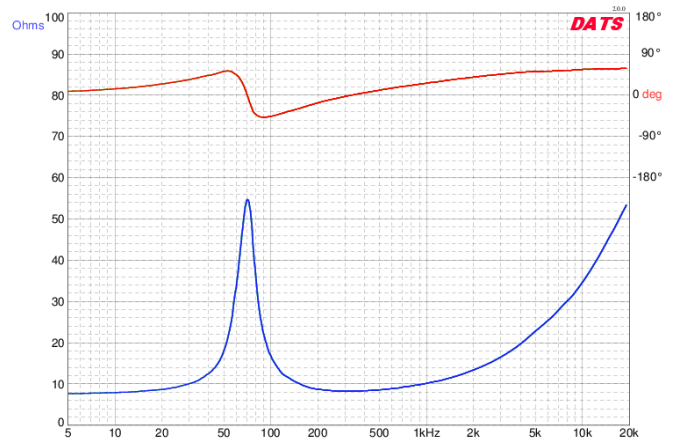

## FREQUENCY RESPONSE

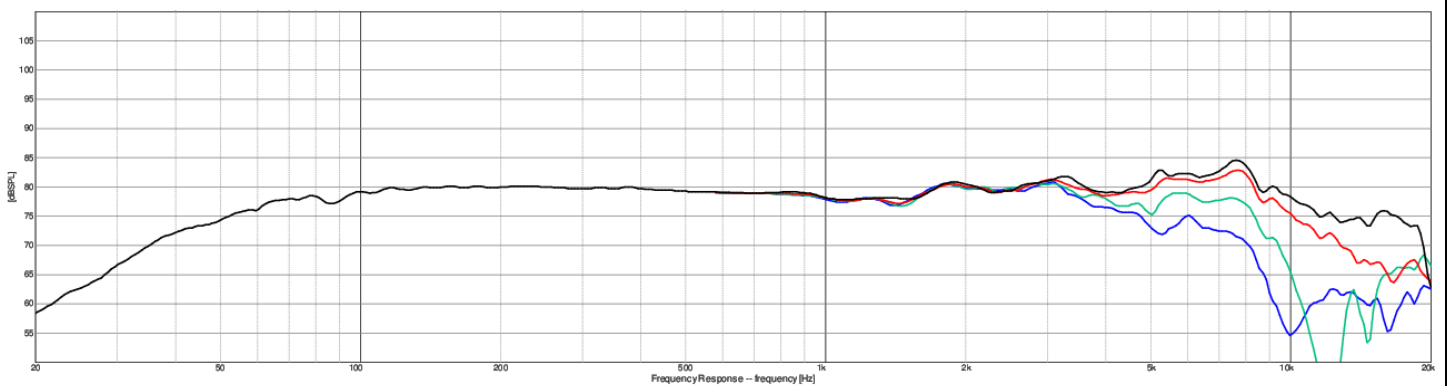

Note: 1/24<sup>th</sup> octave smoothing - nearfield response included in graph below 450 Hz.

Black = 0°  
Red = 15°  
Green = 30°  
Blue = 45°